

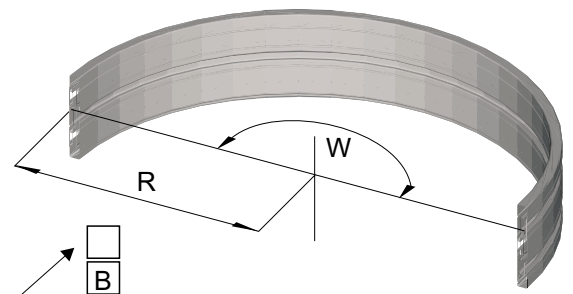

12 x 87,5
12 x 100

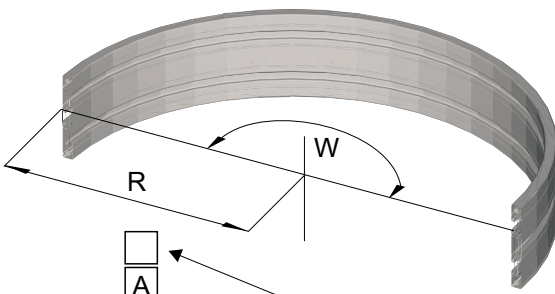
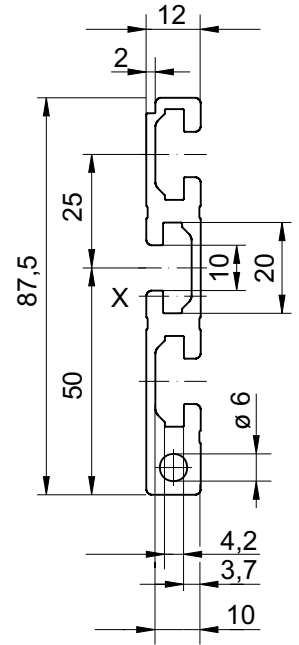
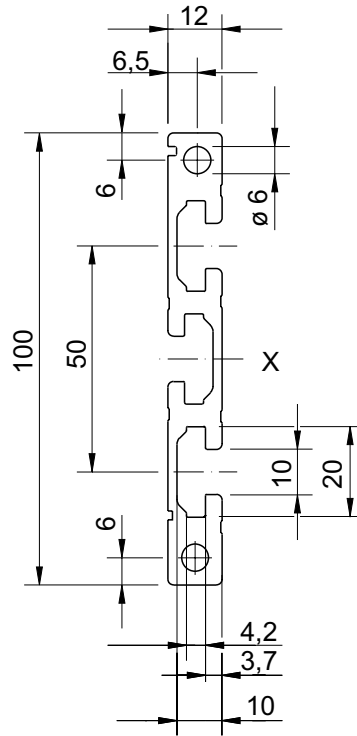

W	° (max. 360°)	R	mm	12 x 87,5	12 x 100
				2898	2798
1 x 6000 mm				2800	2700
10 x 6000 mm				2801	2701
				2802/ mm	2702/ mm
				2899/ mm	2799/ mm

Nach Bearbeitungsliste Seite 1.0.9-1.0.11 bzw. nach Ihrer Skizze.
 Compare outline of end finishing page res.1.0.9-1.0.11 according to your own sketch.
 Selon sommaire de usinage des extrémités page 1.0.9-1.0.11, ou de vortre propre dessin.
 Conforme alla tabella lavorazione delle estremità pagina 1.0.9-1.0.11, rispet. schizzo costruttivo.
 Ver lista de mecanizar los extremos pagina 1.0.9-1.0.11 o bien segun un esbozo de Ud.