

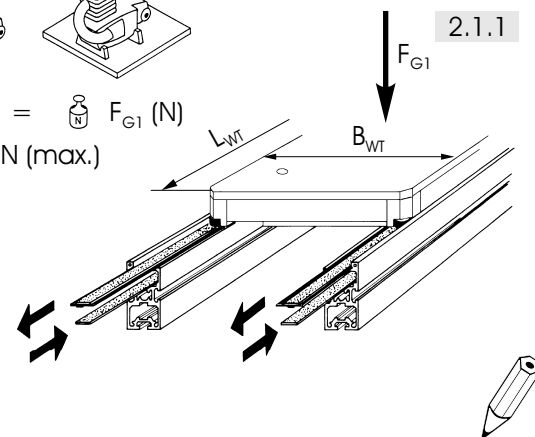

**Doppelgurtförderer, leichte Baureihe**  
**Double-belt conveyor for reduced loads**  
**Convoyeur a bandes jumelées, gamme légère**  
**Trasportatore a nastro doppio, Tipo di costruzione leggera**  
**Accionamiento de doble banda, versión ligera**

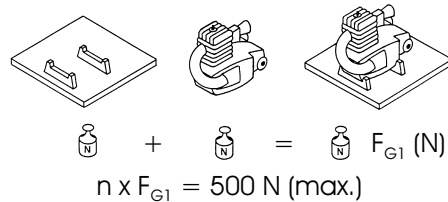
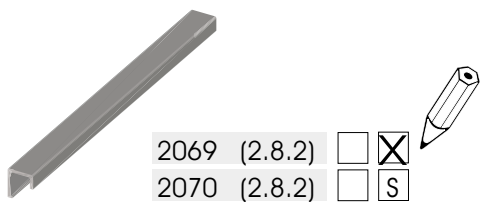
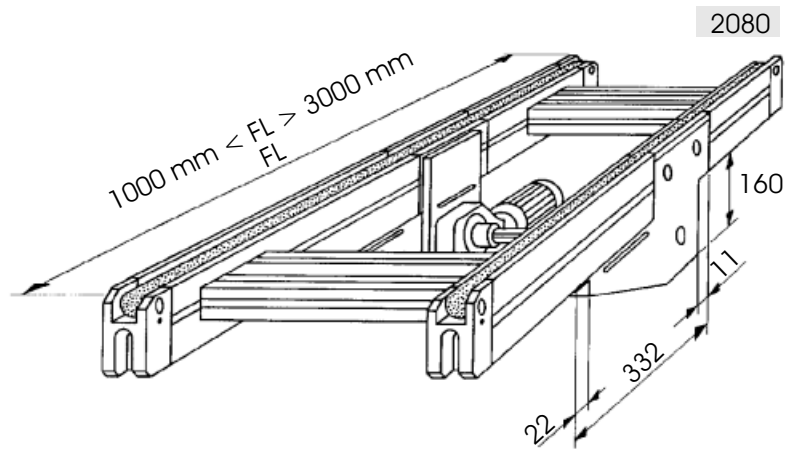
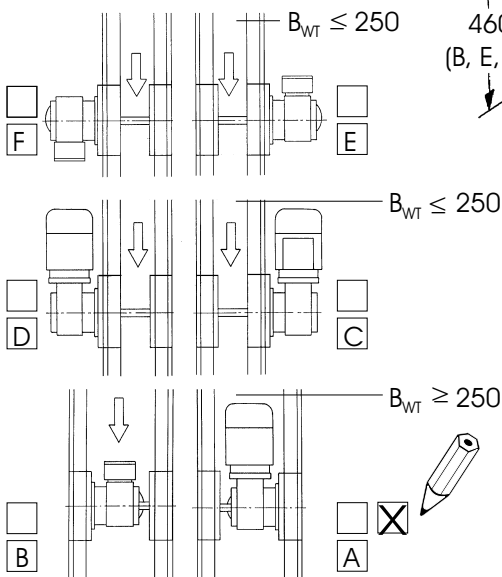
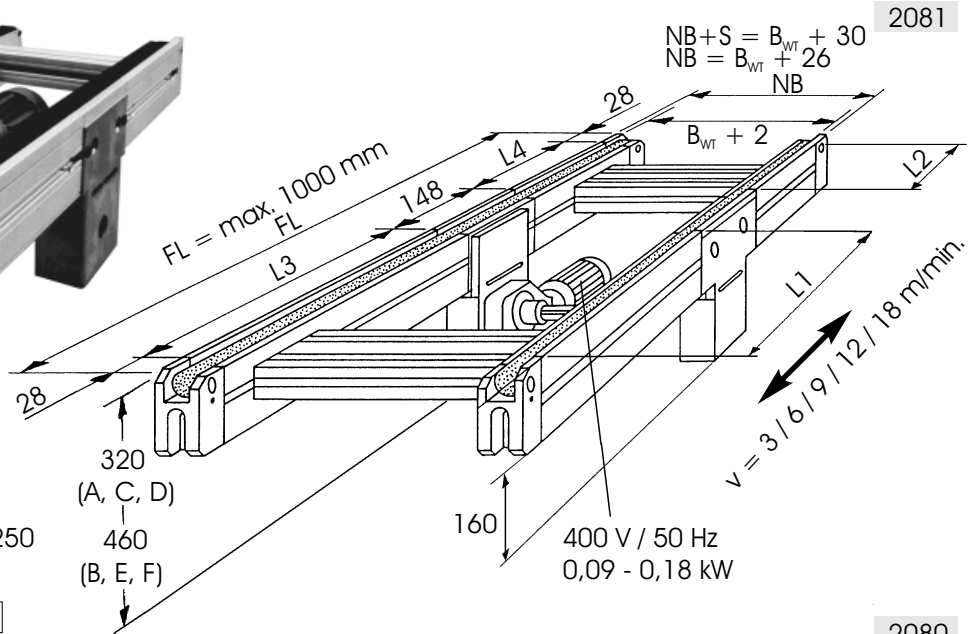

$L_{WT}$	mm
$B_{WT}$	mm
$F_{G1}$	N
$n \times F_{G1}$	N
$FL$	mm
$L_1$	mm
$L_2$	mm
$L_3$	mm
$L_4$	mm
$v$	m/min

$1000 \text{ mm} < FL < 3000 \text{ mm}$	<b>2080</b>	<input type="checkbox"/>
$FL = \max. 1000 \text{ mm}$	<b>2081</b>	<input type="checkbox"/>



**Eingurtförderer, leichte Baureihe**  
**Single-belt conveyor for reduced loads**  
**Convoyeur à bande, gamme légère**  
**Trasportatore a nastro semplice, Tipo di costruzione leggera**  
**Accionamiento de 1 bande, versión ligera**

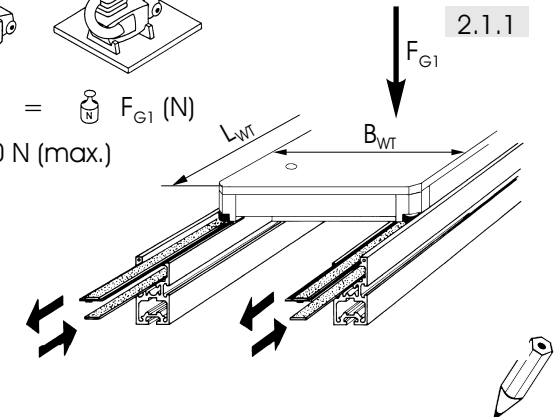
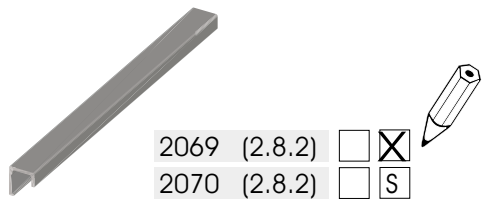
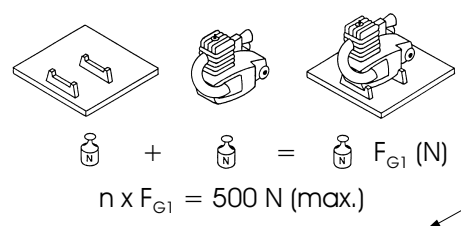
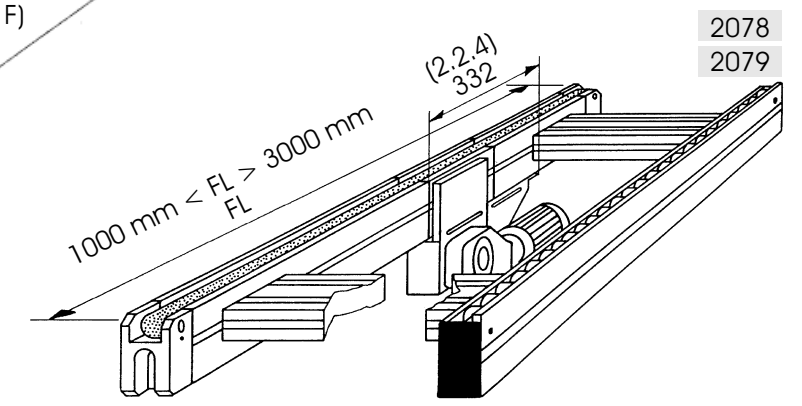
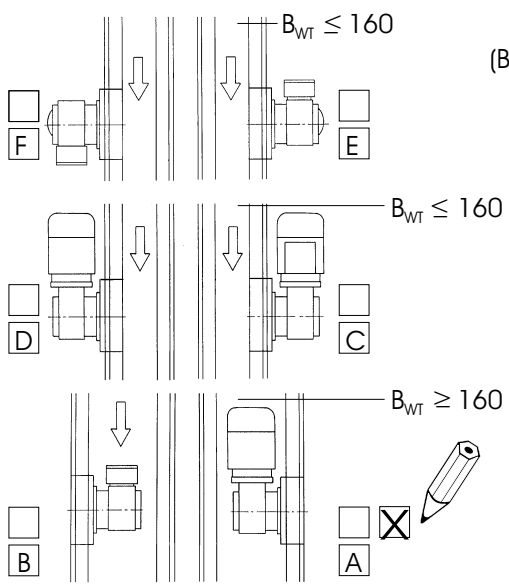
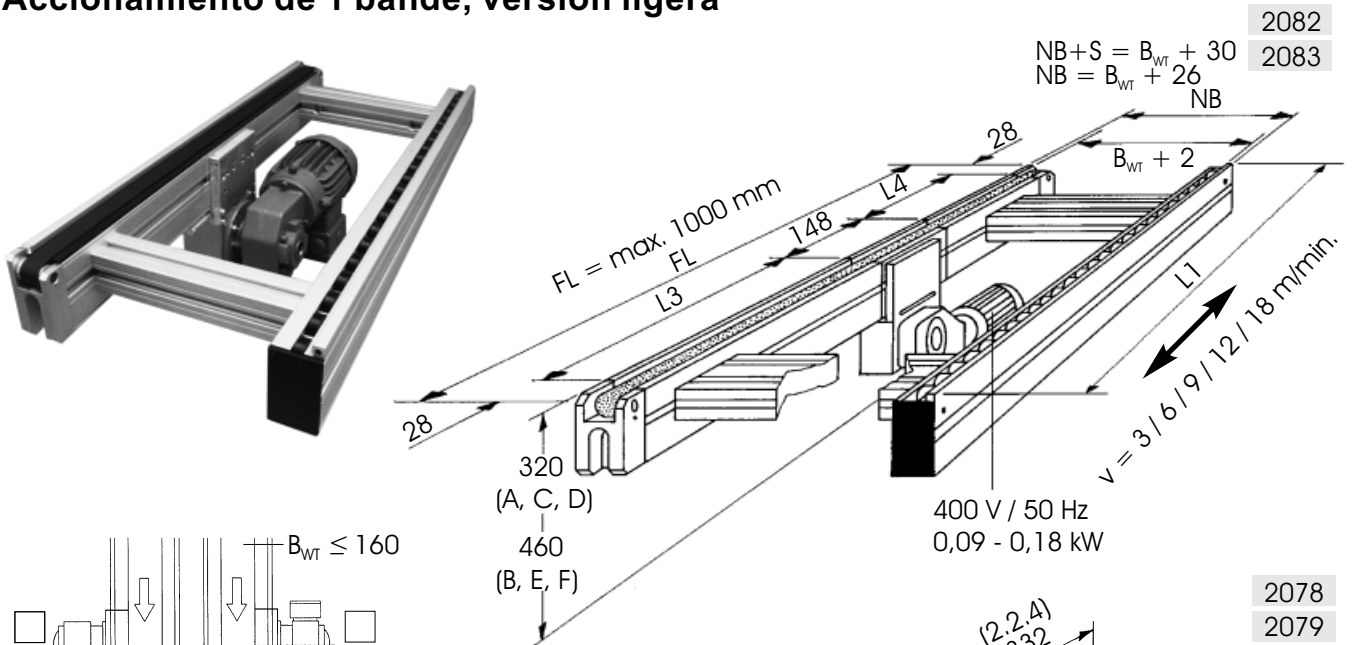

$L_{WT}$		mm
$B_{WT}$		mm
$F_{G1}$		N
$n \times F_{G1}$		N
$FL$		mm
$L_1$		mm
$L_3$		mm
$L_4$		mm
$v$		m/min

	1000 mm < FL > 3000 mm	<b>2078</b>	<input type="checkbox"/>
	1000 mm < FL > 3000 mm	<b>2079</b>	<input type="checkbox"/>
	FL = max. 1000 mm	<b>2082</b>	<input type="checkbox"/>
	FL = max. 1000 mm	<b>2083</b>	<input type="checkbox"/>



**Staurollenkettenträger, leichte Baureihe**  
**Roller-chain conveyor for reduced loads**  
**Chaîne Transporteur d'accumulation à rouleaux, gamme légère**  
**Trasportatore con catena a rulli, Tipo di costruzione leggera**  
**Accionamiento de doble cadena de rodillos, versión ligera**

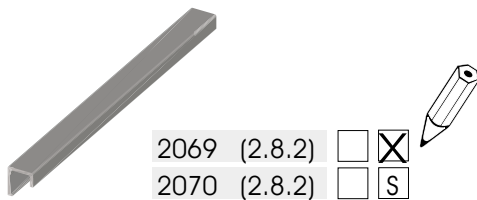
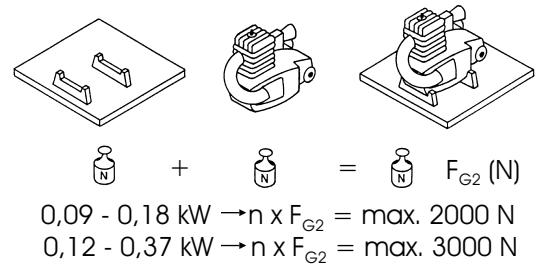
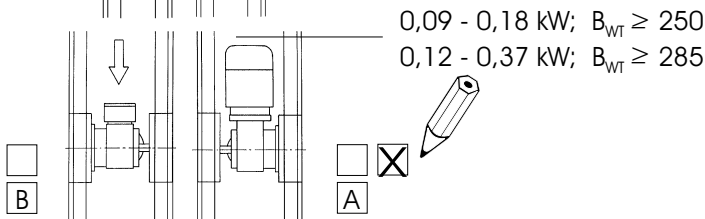
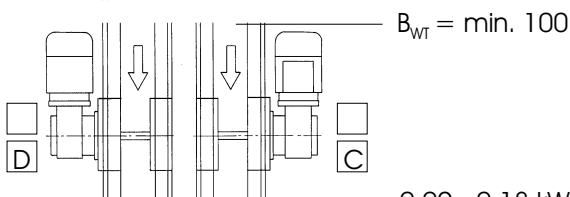
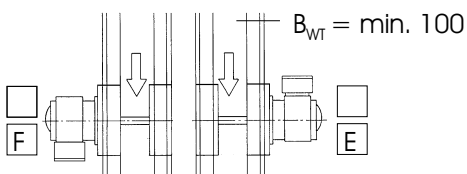
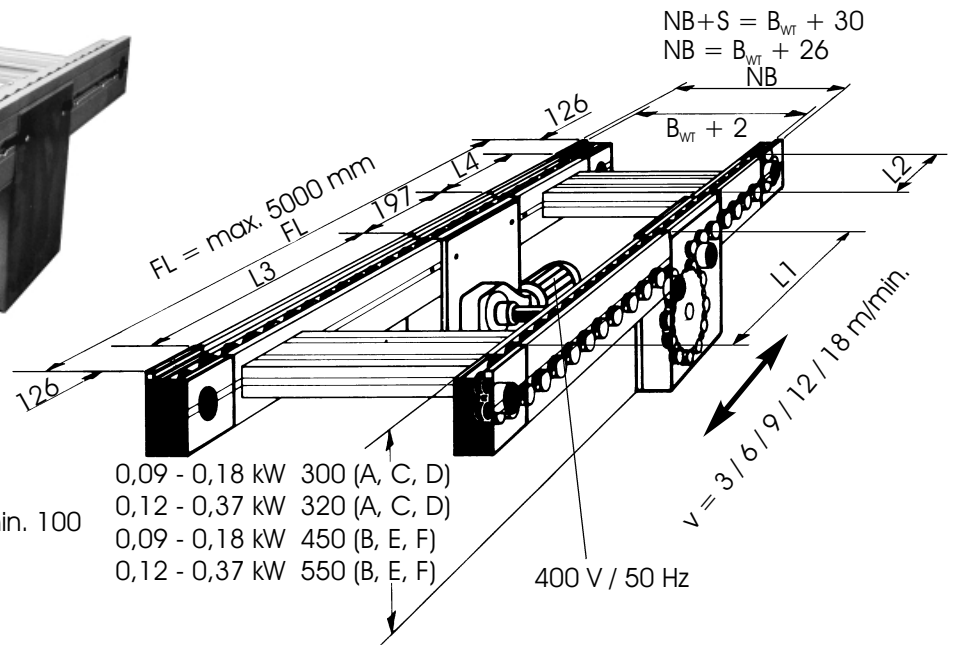

$L_{WT}$	mm
$B_{WT}$	mm
$F_{G2}$	N
$n \times F_{G2}$	N
FL	mm
$L_1$	mm
$L_2$	mm
$L_3$	mm
$L_4$	mm
v	m/min

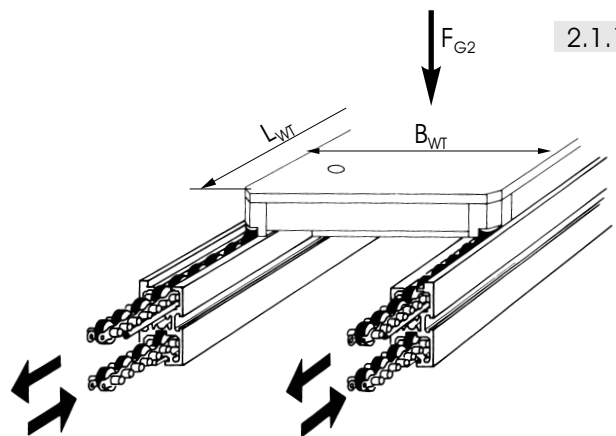

0,09 - 0,18 kW	<b>2084</b>	<input type="checkbox"/>
0,12 - 0,37 kW	<b>2085</b>	<input type="checkbox"/>