

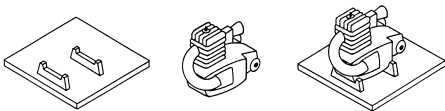

Schleppteller-Fertigungszelle 0°, 360°
Unit for production by transportation disk
Plateau remorqué - Cellule de montage
Stazione con ruota motorizzata
Plato de arrastre - Sélula de montaje

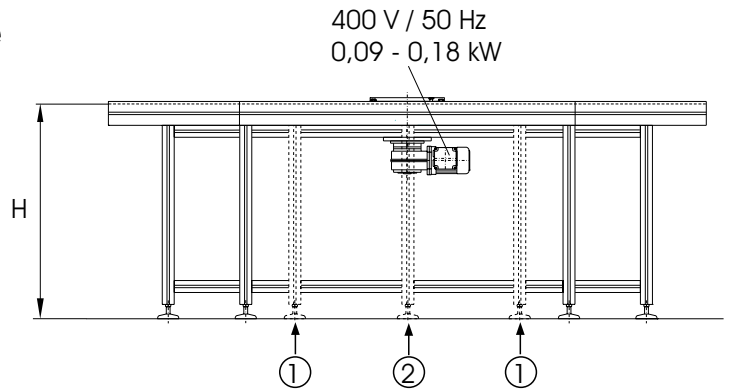

$F_{G1} \text{ (N)}$
 $F_{G1} = 500 \text{ N (max.)}$

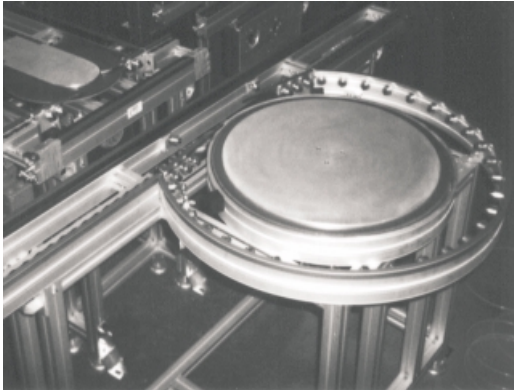
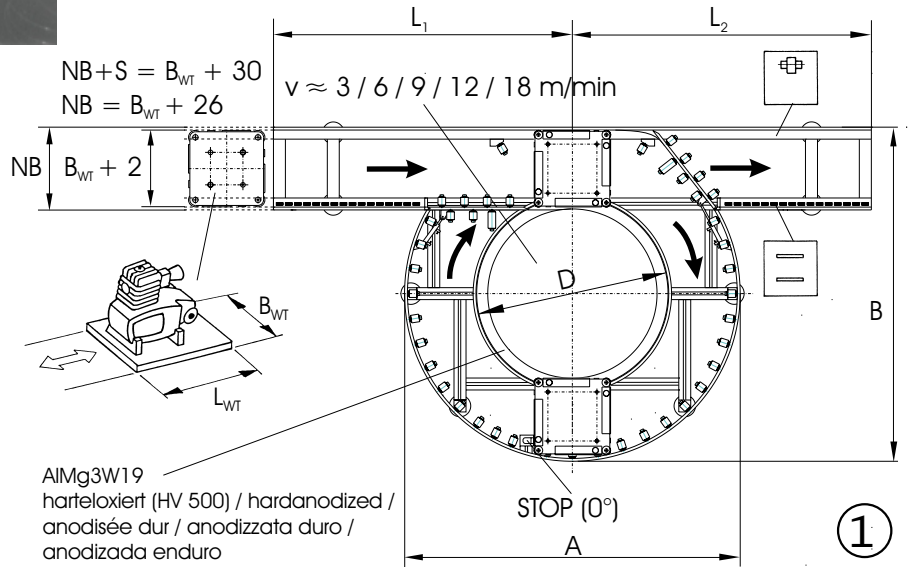
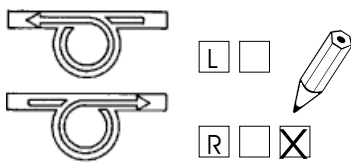

- 2069 (2.8.2)
- 2070 (2.8.2)

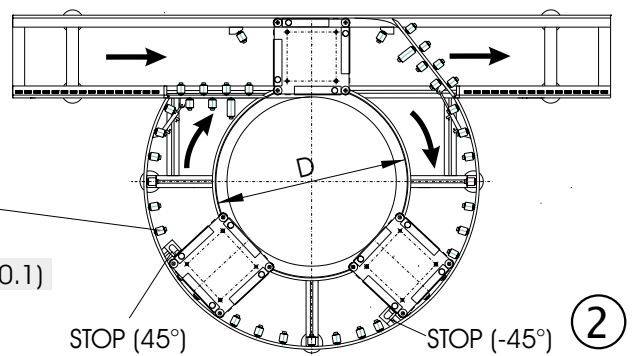
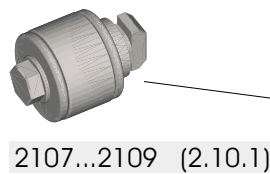

L_{WT}		mm
B_{WT}		mm
F_{G1}		N
A		mm
B		mm
L_1		mm
L_2		mm
H		mm
v		m/min

D (mm)	*) $B_{WT} \times L_{WT}$ (mm) $B_{WT} \leq L_{WT}$	*) A (mm) B (mm)	①	②
680	150...320 x 150...320	920...1285 925...1280	2413	2414
800	150...370 x 150...370	1040...1510 1045...1500	2418	2419
995	150...440 x 150...440	1235...1855 1240...1840	2420	2421

*) Andere Abmessungen auf Anfrage / other measurements for inquiry / Autres dimensions sur demande / Altre misure a richiesta / Consultar otras medidas